



Special Board Meeting

Board Room

May 9, 2022

Fruitport Community Schools
SPECIAL BOARD MEETING
Monday, May 9, 2022 – 5:00 p.m.
Board of Education Meeting Room
3255 E. Pontaluna Rd.
Fruitport, MI 49415

AGENDA

- I. CALL to ORDER**
- II. ROLL CALL**
- III. APPROVAL OF AGENDA**
- IV. REMARKS FROM THE PUBLIC***
- V. GENERAL BOARD BUSINESS**
 - 1. Approval of the Workshop Meeting Minutes from April 19, 2022 (attachment V-1)
 - 2. Letter of Agreement with the Fruitport Education Association (attachment V-2)
 - 3. Change Order (attachment V-3)
 - 4. Other
- VI. ADJOURNMENT**

***Time is provided for members of the audience to address the Board of Education regarding any topic including items on the agenda. The board is providing one opportunity for the public to comment during the meeting. Members of the audience may wish to bring issues to the Board of Education for board consideration. Time limits may be placed if a large number of individuals would like to address the board.**

BOARD ACTION REQUEST FORM

Meeting Date: May 9, 2022

To: Board of Education

Attachment # V-1

From: Jason Kennedy

Subject to be Discussed and Policy Reference:
Board Workshop Minutes from April 19, 2022

Background Information:
n/a

Financial Impact:
n/a

Recommended Action:
To approve the Board Workshop minutes as presented.

Action Taken:

Vote: ___ Buckner ___ Burgess ___ Cole ___ Franklin ___ Hazekamp
 ___ Kelly ___ Meeuwenberg



- I. The Board Workshop was **called to order** at 5:55 p.m. by Board President, Dave Hazekamp.
- II. **ROLL CALL:** Present – Elroy Buckner, Tim Burgess, Kris Cole, Dave Hazekamp, Steve Kelly, and JB Meeuwenberg. Absent - Susan Franklin.

III. APPROVAL OF AGENDA

Item 22-054. MOTION by Cole, SECOND by Burgess to approve the agenda with the addition of Item #6. *Overnight Trip Request - Softball.*

MOTION CARRIED 6-0

IV. GENERAL BOARD BUSINESS

1. April 18, 2022 Regular Meeting Minutes

Item 22-055. MOTION by Burgess, SECOND by Cole to approve the April 18, 2022 Regular Meeting Minutes.

MOTION CARRIED 6-0

2. MASB Board Briefing: Overview of the Superintendent Evaluation

An overview of the Superintendent Evaluation was discussed.

3. MASB Superintendent Evaluation Tool

The MASB Superintendent Evaluation Tool was shared.

4. Discussion and Feedback: Superintendent Performance

The Board discussed an overview of the superintendent's performance during the past six months. The Board is setting a goal to meet again in the fall to begin the formal Superintendent Evaluation.

5. Goal Setting and Strategic Planning

This agenda item was tabled for a future meeting.

6. Overnight Trip Request – Softball

Item 22-056. MOTION by Buckner, SECOND by Cole to approve the Softball overnight trip request April 29-30 in Kalkaska, MI.

MOTION CARRIED 6-0

7. Other

The Board had a discussion about student behavioral issues in the district.

V. REMARKS FROM THE PUBLIC

None.

VI. ADJOURNMENT

Item 22-057. MOTION by Buckner, SECOND by Cole to adjourn.
MOTION CARRIED 6-0

The meeting adjourned at 7:01 p.m.

Respectfully submitted,

Steve Kelly
Board Secretary

BOARD ACTION REQUEST FORM

Meeting Date: May 9, 2022

To: Board of Education

Attachment # V-2

From: Mark Mesbergen

Subject to be Discussed and Policy Reference:
Fruitport Education Association Letter of Agreement

Background Information:

As the teacher candidate pool continues to decrease, Central Office is looking to make sure that we have every tool in the tool box to get the best candidate possible here at Fruitport. Part of the FEA contract states that we cannot count private school years of service when determining what step a candidate can be offered. When talking with the union, they agreed to strike this language through for this year to see if we are able to attract the best talent that we possibly can.

Financial Impact:

Unknown as we could offer candidates additional steps based on counting their private school years of service.

Recommended Action:

To approve the letter of agreement with the Fruitport Education Association as presented.

Action Taken:

Vote: ___ Buckner ___ Burgess ___ Cole ___ Franklin
 ___ Hazekamp ___ Kelly ___ Meeuwenberg

LETTER OF AGREEMENT
FRUITPORT EDUCATION ASSOCIATION,
and the
FRUITPORT COMMUNITY SCHOOLS

RE: Article 4(B)

The Board recognizes four (4) years of outside teaching experience on the salary schedule. The Board, at its discretion, may grant credit in excess of four (4) years on the salary schedule to certificated teachers based on outside teaching or other comparable experience which relates to the teacher's assignment. For the purpose of salary schedule credit only, outside teaching experience gained while on layoff shall be treated as if it were teaching experience in this District. Outside teaching experience shall be limited to time spent teaching in a public school.

The above-named parties hereby agree to the following:

1. It is agreed to strike through "Outside teaching experience shall be limited to time spent in a public school."
 - a. This is only for the hiring of staff for the 2022-2023 school year.
2. All other sections of the Fruitport Education Association's contract are unchanged.

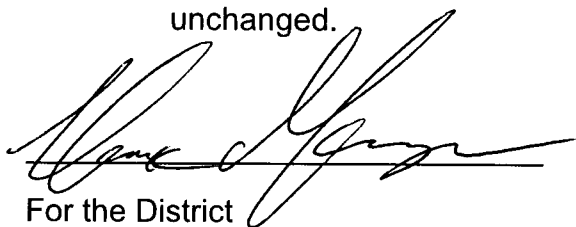
For the District

Dated: 5/5/22

For the Association

Dated: May 3, 2022

BOARD ACTION REQUEST FORM

Meeting Date: May 9, 2022

To: Board of Education

Attachment # V-3

From: Mark Mesbergen

Subject to be Discussed and Policy Reference:

Athletic Field Change Order

Background Information:

When the athletic field design was originally approved, it was done so with the understanding additional scope may need to be included once the soil borings, percolation tests and coefficients were determined, and a thorough review of the plans were completed by engineers. The timing of the project was expedited to help us complete the project on schedule. The budget carried \$155,250 in allowance for this specific purpose. It was also known that runoff from the updated parking lot would need to be accommodated, but it was not fully known until the soil structure had been exposed once work by McCormick had begun and the review of our plans were returned by the county engineer. Now that work has begun, earth has been moved, and review comments have been returned, it is now understood that a significant dewatering cost may be necessary for work to continue, along with the need for additional drainage material below the turf. The water table in the northwest corner of the field is higher than planned for in the design.

Financial Impact:

The total cost of the change order is \$323,420 when you add the OAK fee to Bulletin 01. The board approved the budget in the December board meeting, which had an allowance of \$155,250 for this situation. The pricing came back higher than budgeted. Therefore, the total amount that will impact the contingency is \$168,170.

Recommended Action:

To approve the change order that is attached as presented.

Action Taken:

Vote: ___ Buckner ___ Burgess ___ Cole ___ Franklin ___ Hazekamp
 ___ Kelly ___ Meeuwenberg

May 4, 2022

Ms. Brenda M. Moore
Muskegon County Water Resources Commissioner
141 Apple Avenue, 2nd Floor
Muskegon, MI 49442

RE: 2nd Site Plan Review for Storm Water Management
Fruitport Community Schools- Athletics Improvements
3255 E. Pontaluna Road, Fruitport, MI
Project No. 14028, Task #179

Dear Ms. Moore:

At your request, Eng. has performed a 2nd site plan review for storm water management per the Muskegon County Site Developments Rules, Revised February 2021 (hereinafter referred to as “the Rules”) for the proposed Fruitport Community Schools Athletics Improvements on Parcel #61-15-135-200-0011-00 and 61-41-150-007-0001-00 located at 3255 E. Pontaluna Road in Fruitport, Muskegon County. We reviewed drawings (March 29, 2022) and drainage calculations (dated February 11, 2022) prepared by Holland Engineering.

The revised drawings and calculations have adequately addressed concerns outlined in our previous review letter dated January 18, 2022 and emails sent between April 29, 2022 and May 4, 2022.

We recommend storm water management approval be granted upon receipt at your office of a complete set of the approved drawings and calculations.

The above letter was prepared to assist the MCWRC office in their review of this Project's Storm Water Management Plan. It is not an approval and is not to be used by anyone as the Muskegon County Water Resources Commissioner's Approval Letter.

Please feel free to contact our office with any questions. Thank you.

Sincerely,

Eng., Inc.



Joseph W. Westerbeke, PE
Project Manager

cc: Jason Kennedy (Fruitport Community Schools)
Matt Hulswit, (Owen-Ames-Kimball)
Rebecca Page, P.E. (Holland Engineering, Inc.)
Justin Clish (Village of Fruitport)
Todd Dunham (Fruitport Township)
Ryan McEnhill, P.E. (Eng., Inc.)

S.E.S.C. LEGEND
MICHIGAN UNIFIED KEYING SYSTEM

E8	PERMANENT SEEDING		Stabilization method utilized on sites where earth change has been completed (final grading allowed).
E12	RIPRAP		Use along streambanks, waterways, or where concentrated flow occurs. Stone should be reduced sediment load, and prevent erosion.
S51	SILT FENCE		Use adjacent to critical areas, to prevent sediment laden sheet flow from entering these areas.
S58	INLET PROTECTION FABRIC DROP		Use at stormwater inlets, especially at construction sites.

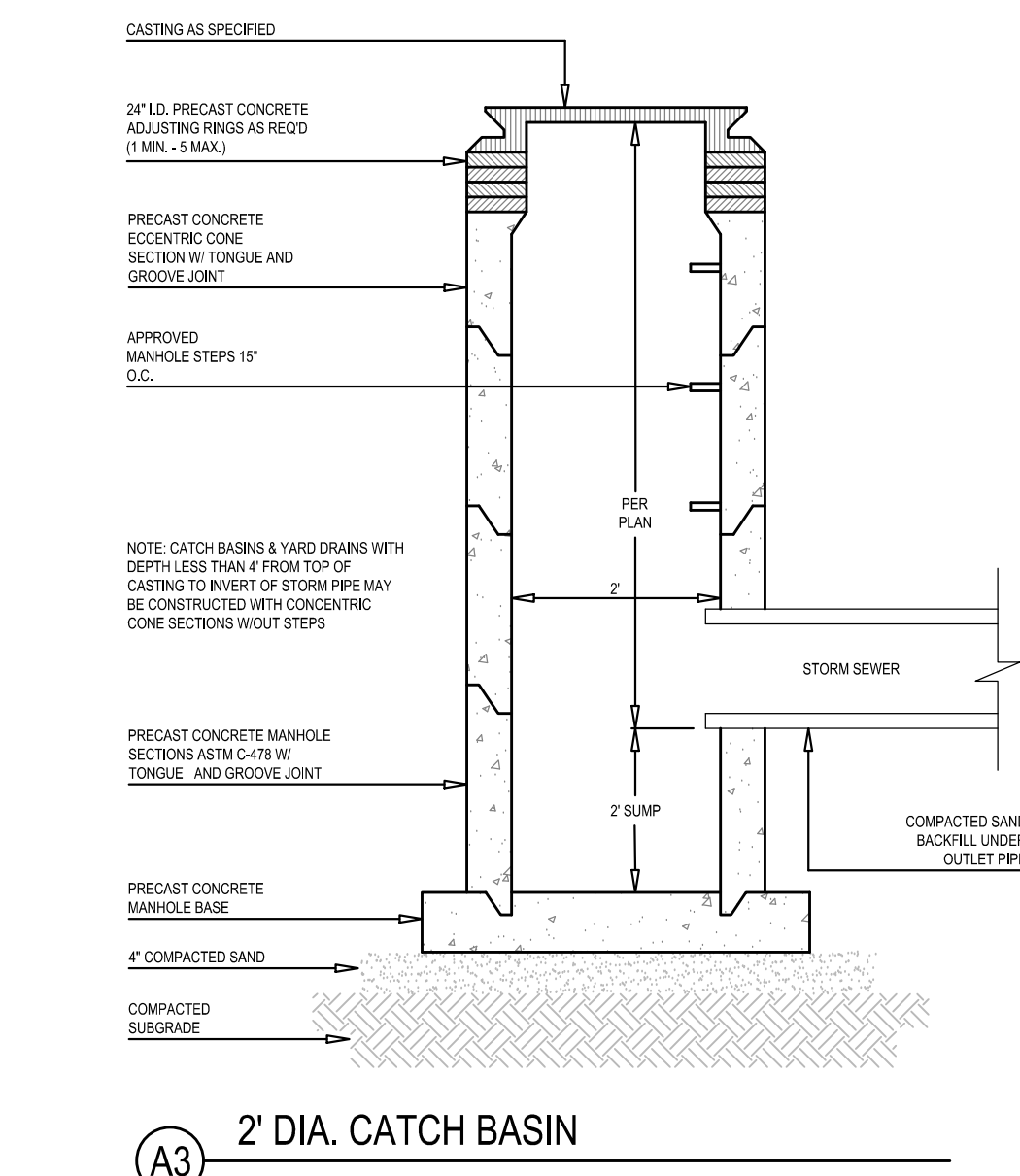
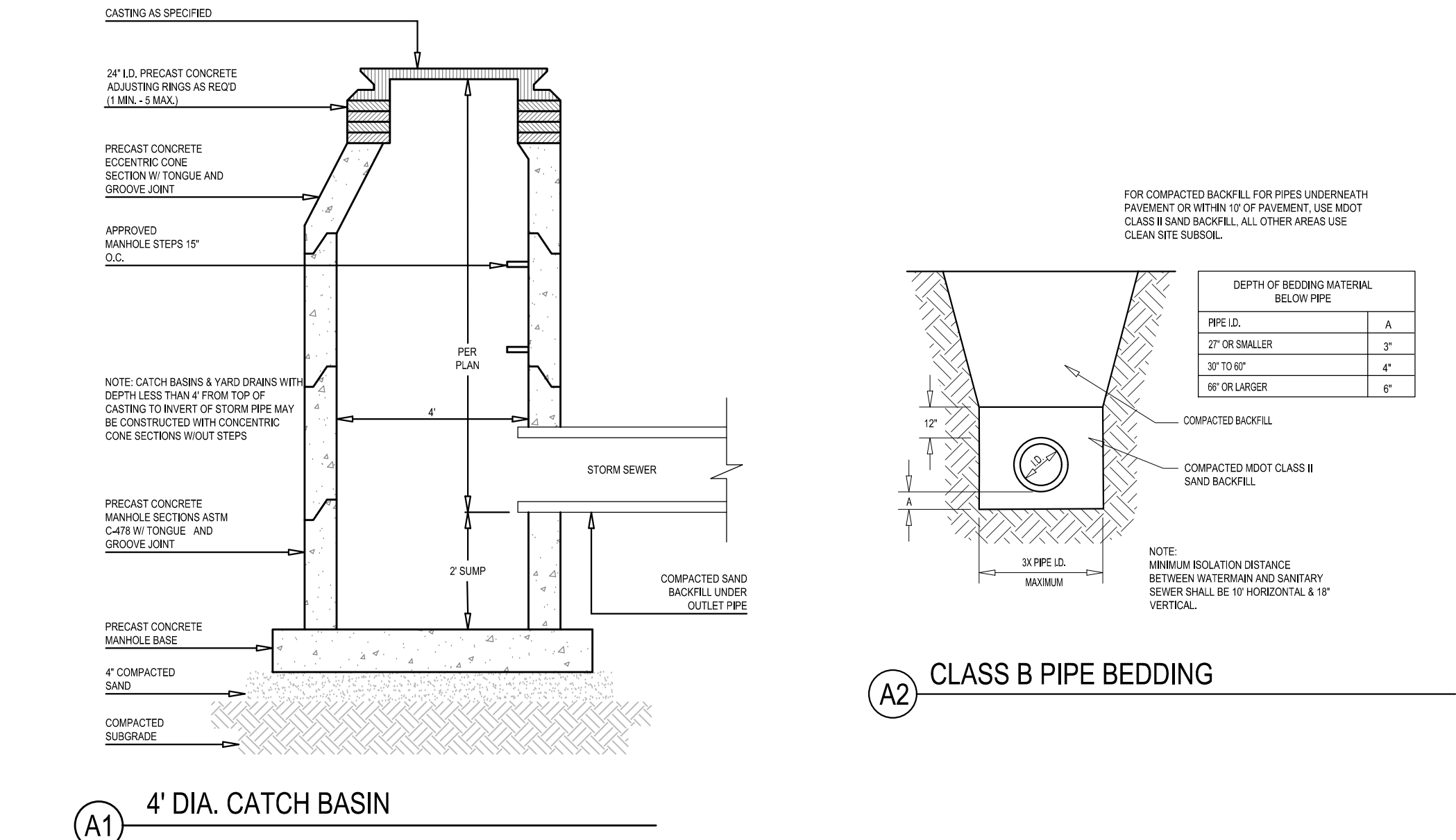
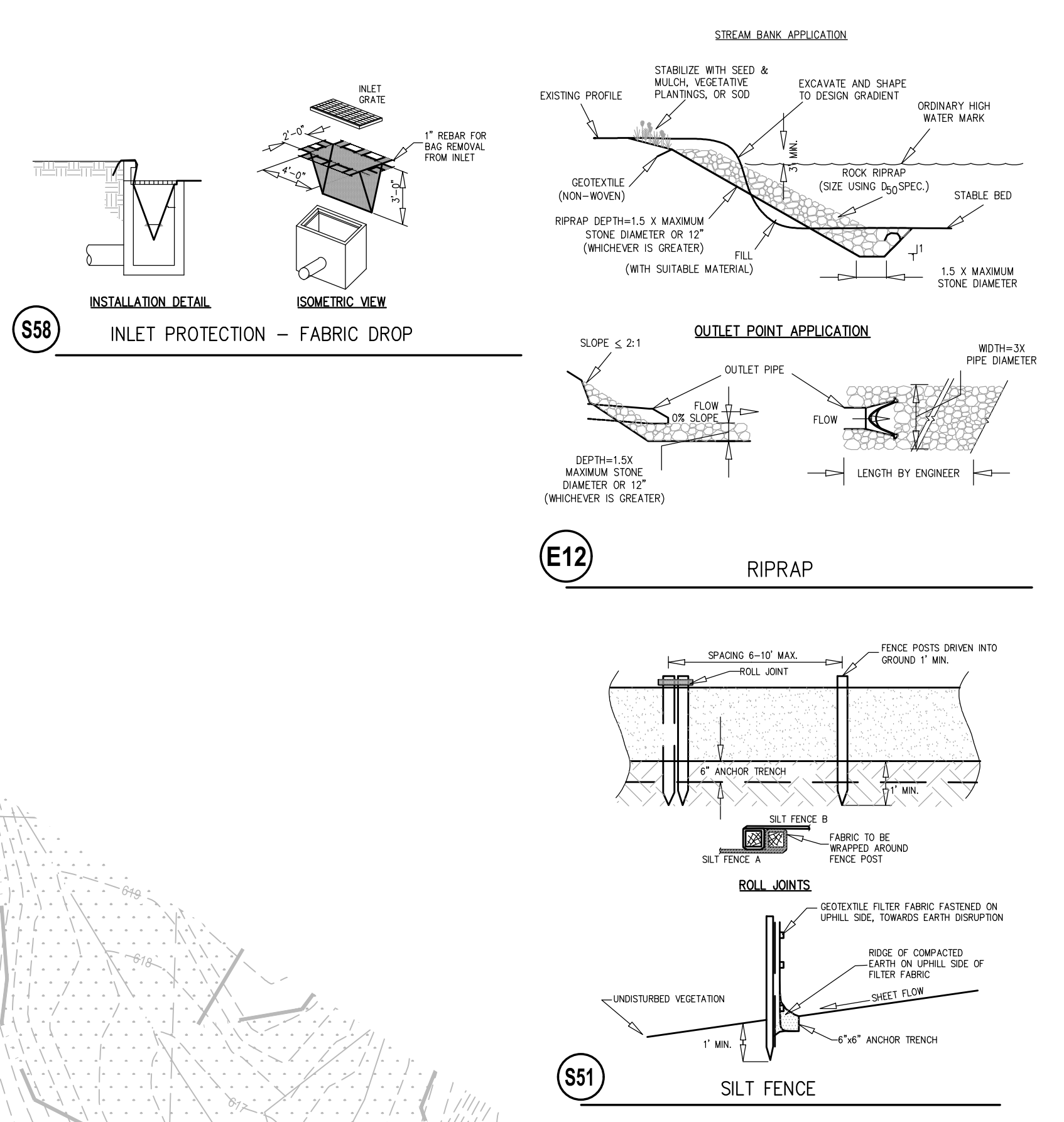
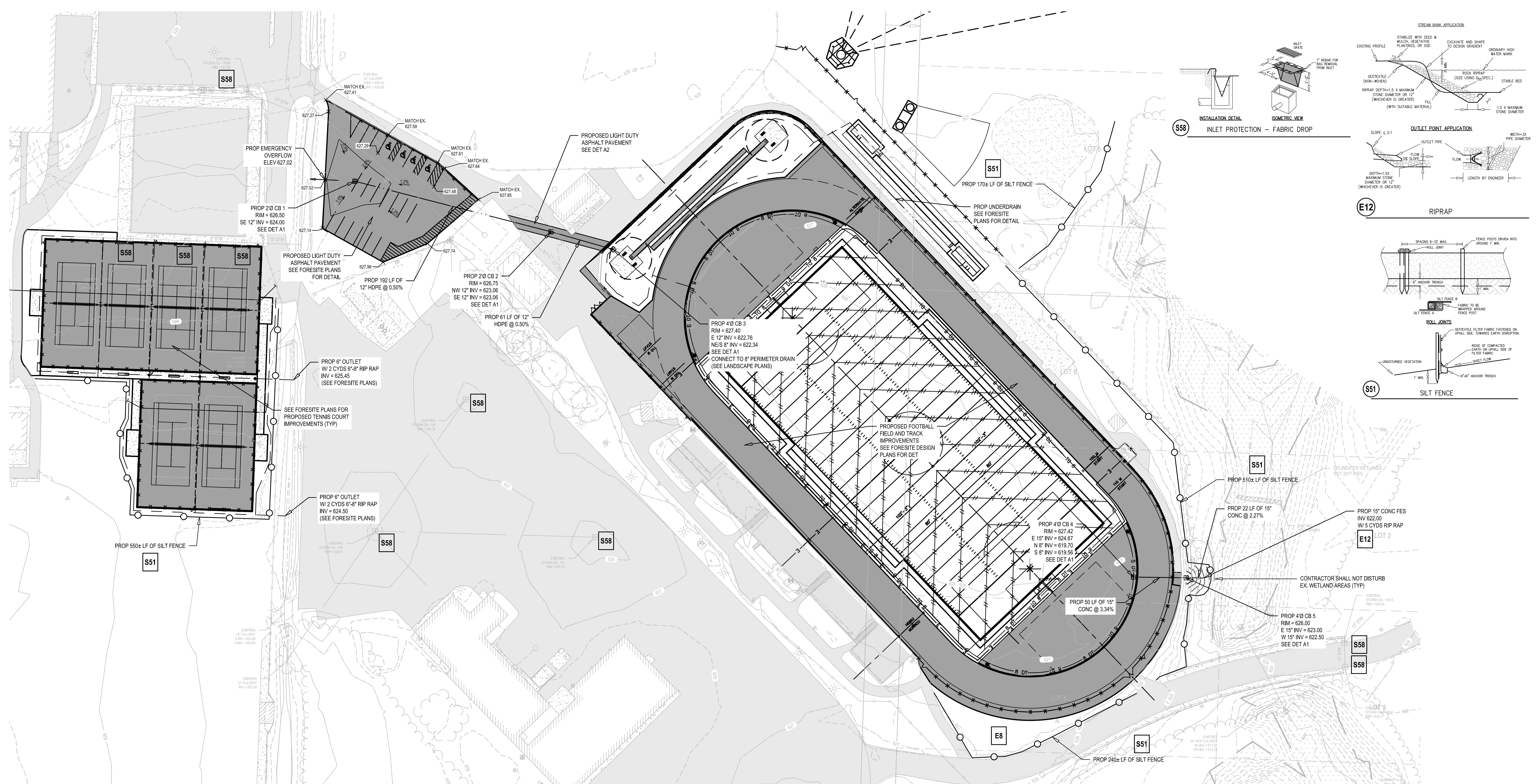
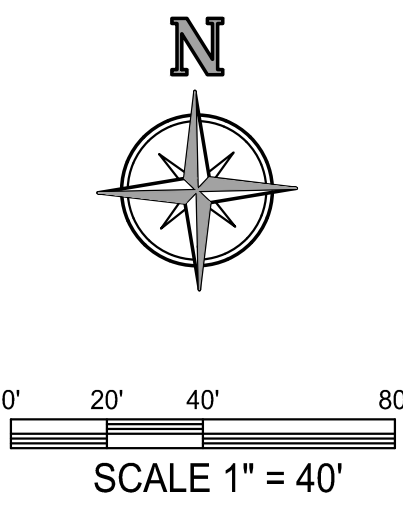

- GRADING & STORM SEWER NOTES:**
- IT IS THE CONTRACTOR'S RESPONSIBILITY TO VERIFY THAT ALL NECESSARY PERMITS AND APPROVALS HAVE BEEN ACQUIRED PRIOR TO CONSTRUCTION.
 - THE DESIGN WAS DEVELOPED IN ACCORDANCE WITH THE INFORMATION CONTAINED IN THE GEOTECHNICAL REPORT AND SOIL BORINGS COMPLETED FOR THE PROJECT. CONTRACTOR SHALL ACQUIRE A COPY OF THE GEOTECHNICAL REPORT AND SOIL BORING INFORMATION. SOIL CONDITIONS MAY VARY FROM THE GEOTECHNICAL INFORMATION, WHICH MAY AFFECT THE SITE DESIGN, EARTHWORK QUANTITIES, USABLE SOILS, AND SOIL EROSION AND SEDIMENTATION CONTROL PRACTICES. CONTRACTOR SHALL NOTIFY DESIGN ENGINEER AND GEOTECHNICAL ENGINEER IF SITE CONDITIONS VARY FROM SOILS INFORMATION CONTAINED IN THE GEOTECHNICAL INFORMATION.
 - CALL, MISS, DIG AT LEAST THREE (3) WORKING DAYS PRIOR TO STARTING ANY EXCAVATION.
 - WETLANDS EXIST WITHIN THE PROPOSED SITE IMPROVEMENTS. CONTRACTOR SHALL NOT DISTURB THE WETLAND AREAS, UNLESS PERMITTED BY THE EGLE. CONTRACTOR SHALL COMPLETE ALL WETLAND DISTURBANCE WORK IN ACCORDANCE WITH THE EGLE / USACE JOINT PERMIT AND EGLE STANDARDS AND REQUIREMENTS. IT IS THE CONTRACTOR'S RESPONSIBILITY TO ACQUIRE A COPY OF THE EGLE / USACE JOINT PERMIT.
 - CONTRACTOR SHALL VERIFY THAT THERE ARE NO UTILITY CONFLICTS PRIOR TO CONSTRUCTION.
 - ALL WORK WITHIN THE RIGHT-OF-WAY WILL REQUIRE A PERMIT AND OR APPROVAL FROM VILLAGE OF FRUITPORT AND SHALL BE CONSTRUCTED IN ACCORDANCE WITH THE CURRENT EDITION OF THEIR STANDARDS & SPECIFICATIONS.
 - STORM WATER MANAGEMENT SYSTEM AND GRADING SHALL BE IN ACCORDANCE WITH THE MUSKOGEE COUNTY WATER RESOURCES COMMISSION STORM WATER ORDINANCE.
 - CONTRACTOR RESPONSIBLE TO CONNECT STORM / ROOF WATER TO STORM DRAIN AS SHOWN. REFER TO PLUMBING PLANS FOR CONNECTION TO THE BUILDING AND DETAILS.
 - SITE SHALL BE GRADED WITH SMOOTH CONTOURS IN ALL AREAS OF DISTURBANCE AND GRADED TO SLOPE AWAY FROM THE EXISTING AND PROPOSED BUILDINGS AND SIDEWALKS.
 - ALL STORM SEWER PIPING SHALL BE ADS #42, HANCOCK HQ-2 OR APPROVED EQUIVALENT POLYETHYLENE (PE) PLASTIC PIPE AND FITTINGS, UNLESS OTHERWISE NOTED WHERE SPECIFIED IN THE PLANS. CONCRETE CLASS IV PIPE WITH RUBBER GASKETS IS REQUIRED.
 - SEE LANDSCAPE PLANS FOR LANDSCAPING UNDERDRAIN SYSTEM REQUIREMENTS.
 - SEE OTHER SHEETS IN PLAN SET FOR MORE INFORMATION.

Project Manager
REBECCA PAGE, P.E.

Drawn by
COLLIN DEPREKEL

HEI Project Number
16-12-008

The Surveyor's / Engineer's liability for any and all claims, including but not limited to those arising out of the Surveyor's / Engineer's professional services, negligence, gross misconduct, warranties or misrepresentations shall be deemed limited to an amount no greater than the service fee.

HOLLAND ENGINEERING

220 Hoover Boulevard
Holland, Michigan 49423-3766
www.hollandengineering.com
T 616-392-6938 F 616-392-2116

Fruitport - Turf & Athletic Improvements

Bulletin 01

\$ 312,483.00

5/2/2022

		Bulletin 01												
		Item 1	Item 2	Item 3	Item 4	Item 5	Item 6	Item 7	Item 8	Item 9	Item 10	Item 11	Item 12	Totals
Bid Category	Contractor	Site Clearing specification [Clarification]	Earth Moving specification [Clarification]	Replacing Subdrainage Systems – Peastone with a more comprehensive specification section. [Design Change]	Replacing Subdrainage Systems – Peastone with a more comprehensive specification section. [Design Change]	Stadium Irrigation [Design Change]	Demolition for storm sewer [Design Change]	Sideline turf logo [Design Change]	Drainage at stadium [Design Change]	Water Distribution for Turf [Design Change]	Parking lot grading [Design Change]	Parking lot drainage [Design Change]	Grading & Storm Sewer Plan [Design Change]	
Bid Category No.01 – Synthetic Turf	SprinTurf							NC	\$ 177,622.00					\$ 177,622.00
Bid Category No.02 – Earthwork	McCormick Sand					\$ 2,628.00	\$ 3,893.00		\$ 72,435.00	\$ 2,515.00	\$ 7,735.00	\$ 38,535.00	Included in 11	\$ 127,741.00
Bid Category No.03 - Asphalt Paving	LiteLoads												\$ 6,895.00	\$ 6,895.00
Bid Category No.04 - Fencing	M&M Fencing												\$ 225.00	\$ 225.00
Bid Category No.05 - Concrete	Burgess Concrete Construction	NC	NC	NC	NC	NC	NC	NC	NC	NC	NC	NC	NC	\$ -
Bid Category No.06 – Track Coatings	Goddard Coatings	NC	NC	NC	NC	NC	NC	NC	NC	NC	NC	NC	NC	\$ -
Bid Category No.07 – Tennis Coatings	Goddard Coatings	NC	NC	NC	NC	NC	NC	NC	NC	NC	NC	NC	NC	\$ -
														\$ -
	Totals	\$ -	\$ -	\$ -	\$ -	\$ 2,628.00	\$ 3,893.00	\$ -	\$ 250,057.00	\$ 2,515.00	\$ 7,735.00	\$ 38,535.00	\$ 7,120.00	\$ 312,483.00

Lite Load Service LLC
3866- 40th Street
Hamilton, MI 49419
PH: 269-751-6037
Fx: 269-751-4120

Estimate

Date	Estimate #
4/18/2022	2014712

Name / Address
Owen Ames Kimball Co 300 Ionia NW Grand Rapids, MI 49503

Description	Qty	Rate	Total
Project: Fruitport Track Change Order: Bulletin 1 Added Work: Approx. 1100 sf Asphalt Paving (Avg. 3") Fine Grading Avg. 2.5" Base Asphalt (4E1) Avg. 1.5" Top Asphalt (5E1) Material, Labor, and Products BOND FEE'S OR DUES ARE NOT INCLUDED IN QUOTE.IF ANY ARE GOING TO BE CHARGED THEY MUST BE ADDED TO QUOTE. Additional Insurance Coverage Cost- If you are going to request a waiver of subrogation on workers comp- additional cost will be \$100 Terms: Price Based On All Paving Being Completed In The Season 2022. Please Respond within 20 Days. Nights and weekends are not included in bid If paving is not full depth, reflective cracking can and will occur and often in less than a year. LiteLoads is not responsible for reflective cracking.		6,895.00	6,895.00
-Thank you for your business. Office Ph. 269-751-6037 Cell 269-512-4131		Total	\$6,895.00
Thank you for the opportunity to quote your project .All invoices are due upon receipt.After 60 day's a 18% interest will be applied to all outstanding invoices.Quotes are valid for 10 day's.		Authorized Signature	

M&M FENCING, INC.

255 Walter ST SE Wyoming, MI 49548 Phone: (616) 532-9740 Fax: (616) 534-3439
Email: usemmfencing@gmail.com

QUOTATION

DATE: April 18, 2022

To: OAK
Attn: Rick Lineberry
E-mail: RickL@OAKmi.com

**WE ARE PLEASED TO QUOTE YOUR INQUIRY AS FOLLOWS:
PROJECT: Fruitport – Bulletin #1**

DESCRIPTION: M&M Fencing to supply all labor and materials to install the following:

1. Re-install 10' of Chain Link Fencing. Take down existing fence and post.

Total: \$225.00

If you have any questions regarding the above quotation, please feel free to contact Mike by cell phone at (616) 291-5019. We look forward to working with you on this project!!

PREPARED BY: ***Mike Marshall.***

(All quotes are valid for 14 days unless otherwise specified.)

McCormick Sand, Inc. Pricing 4/18/22

BULLETIN NO. 1

DATE OF ISSUANCE: April 4, 2022
PROJECT: Athletic Improvements
OWNER: Fruitport Community Schools
ARCHITECT'S PROJECT NO.: 14-162.24
ORIGINAL BID ISSUE DATE: November 1, 2021

GENERAL NOTICE

This information is issued after release of original Contract to inform the Contractor of the intent to make changes and/or additions to the Project.

This is not an order to proceed. The Contractor shall submit changes in Contract Sum and Contract Time, for each item for approval and direction before proceeding.

If accepted, the Contractor will be required to furnish all materials, labor, and supervision required to properly and completely execute the Work described in that item.

The provisions of the Contract Documents shall govern all Work included herein unless otherwise noted.

DOCUMENTS INCLUDED IN THIS BULLETIN

This Bulletin includes **3** pages of text and the following documents:

- Contract Conditions: **None.**
- Specification Sections: **31 1500, 31 2000, 33 4100**
- Drawings: **L 1.01, L1.02, L1.05, L2.01, L2.04, L2.05, LD1.01, LD1.05 and C201**

BUL-1 Item No. 1 - Site Clearing specification [Clarification]

Refer to Sheet(s): 31 1500

Supplemental information provided to the specification section.

BUL-1 Item No. 2 - Earth Moving specification [Clarification]

Refer to Sheet(s): 31 2000

New specification section for general earth moving information provided for areas outside of athletics.

BUL-1 Item No. 3 - Replacing Subdrainage Systems – Peastone with a more comprehensive specification section. [Design Change]

Refer to Sheet(s): 33 4615 and 33 4100

Delete specification Section 33 4615 Subdrainage Systems - Peastone in its entirety and refer to new, issued 33 4100 Storm Utility Drainage Piping specification.

BUL-1 Item No. 4 - Replacing Subdrainage Systems – Peastone with a more comprehensive specification section. [Design Change]

Refer to Sheet(s): 33 4100

SP

Insert 33 4100 Storm Utility Drainage Piping in its entirety.

BUL-1 Item No. 5 - Stadium Irrigation [Design Change]

Refer to Sheet(s): L1.01

\$ 2,628.-

Abandon existing irrigation system within the stadium in its entirety.

BUL-1 Item No. 6 - Demolition for storm sewer [Design Change]

Refer to Sheet(s): L1.01, L2.01

\$ 3,893.-

Demolition of existing storm pipe and catch basin.

BUL-1 Item No. 7 - Sideline turf logo [Design Change]

Refer to Sheet(s): L1.02, LD1.05

N/C

Revise the sideline logo to fit within the field of play.

BUL-1 Item No. 8 - Drainage at stadium [Design Change]

Refer to Sheet(s): L1.05

\$ 72,435.- Incl. dewatering; may be

Finalized stadium storm sewer design per civil engineering overall site storm sewer design.

reduced if not necessary for all pipe.

BUL-1 Item No. 9 - Water Distribution for Turf [Design Change]

Refer to Sheet(s): L1.05, LD1.01

\$ 2,515.-

Remove irrigation valve boxes, pvc services lines, quick coupler valves, and connection to existing service line from scope of work. Install new non-freeze ground hydrant at potable water source indicated on drawing.

BUL-1 Item No. 10 - Parking lot grading [Design Change]

Refer to Sheet(s): L2.04

\$ 7,735.-

Delete parking lot grading in its entirety. Refer to HEI civil engineering drawings for new parking lot grading.

BUL-1 Item No. 11 - Parking lot drainage [Design Change]

Refer to Sheet(s): L2.05

\$ 38,535.- Incl. dewatering; may be reduced or eliminated if not necessary.

Delete parking lot storm sewer design in its entirety. Refer to HEI civil engineering drawings for new parking lot storm sewer design.

BUL-1 Item No. 12 - Grading & Storm Sewer Plan [Design Change]

Refer to Sheet(s): C201

Included under Item No 11

Proposed parking area grading and storm sewer layout for improvements. Soil erosion and sedimentation control measures are also included on this sheet.

END OF BULLETIN

McCormick Sand, Inc
David P. Van der Meer V.P. 4/18/22

Bulletin 01; Item No 05
Removal of Existing Infield Irrigation System and Related Utilities

Description of Work: Bulletin #1; Section 05 - Investigate, Remove and Abandon irrigation and related utilities within limits of infield subgrade
 Work Dates: April 2022

Labor & Equipment

Description	Labor			Description	Equipment			
	Hours	Rate	Amount		Units	UOM	Rate	Amount
Operator	8.0	\$ 82.00	\$ 656.00	CAT 316FL Excavator	2.0	HR	\$ 103.70	\$ 207.40
Laborer	12.0	\$ 75.00	\$ 900.00	CAT 950H Loader	6.0	HR	\$ 74.61	\$ 447.66
			\$ -					\$ -
			\$ -					\$ -
			\$ -	Crew Pickup	6.0	HR	\$ 25.00	\$ 150.00
			\$ -					\$ -
			\$ -					\$ -
Labor Cost			\$ 1,556.00	Equipment Cost				\$ 805.06

Materials

Description	Qty	UOM	Rate	Amount
				\$ -
				\$ -
				\$ -
				\$ -
				\$ -
				\$ -
				\$ -
				\$ -
				\$ -
				\$ -
				\$ -
				\$ -
				\$ -
Material Subtotal				\$ -
Sales Tax (6%)				\$ -
Materials Cost				\$ -

Subcontractor

Description	Qty	UOM	Rate	Amount
				\$ -
				\$ -
				\$ -
				\$ -
				\$ -
				\$ -
Subcontractor Cost				\$ -

SUMMARY

	Cost	MU%	Markup	Total
Labor & Equipment	\$ 2,361.06	10%	\$ 236.11	\$ 2,597.17
Materials	\$ -	10%	\$ -	\$ -
Subcontractors	\$ -	5%	\$ -	\$ -
Subtotal Cost				\$ 2,597.17
Bond	\$ 2,597.17	1.20%		\$ 31.17
Total Cost				\$ 2,628.33

Bulletin 01; Item No 06
Removal of Existing Infield Storm Drain and Basins

Description of Work: Bulletin #1; Section 06 - Remove, Backfill and dispose of existing catch basins and drain tile around inside perimeter track.
 Work Dates: TBD

Labor & Equipment

Description	Labor			Description	Equipment			
	Hours	Rate	Amount		Units	UOM	Rate	Amount
Operator	12.0	Reg \$ 82.00	\$ 984.00	CAT 316FL Excavator	10.0	HR	\$ 103.70	\$ 1,037.00
Laborer	8.0	Reg \$ 75.00	\$ 600.00	CAT 950H Loader	2.0	HR	\$ 74.61	\$ 149.22
			\$ -					\$ -
			\$ -					\$ -
			\$ -	Crew Pickup	10.0	HR	\$ 25.00	\$ 250.00
			\$ -					\$ -
			\$ -					\$ -
Labor Cost			\$ 1,584.00	Equipment Cost				\$ 1,436.22

Materials

Description	Qty	UOM	Rate	Amount
Rolloff Dumpster	1	LD	\$ 450.00	\$ 450.00
				\$ -
				\$ -
				\$ -
				\$ -
				\$ -
				\$ -
				\$ -
				\$ -
				\$ -
				\$ -
Material Subtotal				\$ 450.00
Sales Tax (6%)				\$ 27.00
Materials Cost				\$ 477.00

Subcontractor

Description	Qty	UOM	Rate	Amount
				\$ -
				\$ -
				\$ -
				\$ -
				\$ -
Subcontractor Cost				\$ -

SUMMARY

	Cost	MU%	Markup	Total
Labor & Equipment	\$ 3,020.22	10%	\$ 302.02	\$ 3,322.24
Materials	\$ 477.00	10%	\$ 47.70	\$ 524.70
Subcontractors	\$ -	5%	\$ -	\$ -
Subtotal Cost				\$ 3,846.94
Bond	\$ 3,846.94	1.20%		\$ 46.16
Total Cost				\$ 3,893.11

Description of Work: Bulletin #1; Section 8 - Reroute Long Jump 6" drintile (add 145'), upsize pole vault 6" drintile to 8" (160'); furnish 3 drainage 48" structures w/ covers, furnish 15" RCP (75ft), 15" Concrete End Section and rip rap for SE corner drainage outlet, gravel patch and slope restoration. Additional excavation and backfill to Increase depth of original proposed drintile to new plan depth (~300 CYD). Excludes restoration of fencing or HMA pavement necessary to construction work related to this item.
 Work Dates: TBD

Labor & Equipment

Description	Labor			Description	Equipment			
	Hours	Rate	Amount		Units	UOM	Rate	Amount
Operator	48.0	Reg \$ 82.00	\$ 3,936.00	CAT 316FL	23.0	HR	\$ 103.70	\$ 2,385.10
Laborer	63.0	Reg \$ 75.00	\$ 4,725.00	CAT 950H	19.0	HR	\$ 74.61	\$ 1,417.59
			\$ -	CAT D5K2	6.0	HR	\$ 46.07	\$ 276.42
			\$ -	Diesel Plate Compactor	10.0	HR	\$ 20.00	\$ 200.00
			\$ -	Pickup	16.0	HR	\$ 25.00	\$ 400.00
			\$ -					\$ -
			\$ -					\$ -
Labor Cost			\$ 8,661.00	Equipment Cost				\$ 4,679.11

Materials

Description	Qty	UOM	Rate	Amount
6" Drain Tile	20	FT	\$ 4.50	\$ 90.00
8" Drain Tile	160	FT	\$ 7.97	\$ 1,275.20
Underdrain Fittings	1	LS	\$ 200.00	\$ 200.00
15" CI IV RCP	82	FT	\$ 17.94	\$ 1,471.08
15" Conc Flared End Section	1	EA	\$ 425.00	\$ 425.00
Peastone	84	TN	\$ 19.00	\$ 1,596.00
Geotextile Fabric	300	SYD	\$ 1.05	\$ 315.00
48" Dia Catch Basin w/ Covers	3	EA	\$ 1,446.00	\$ 4,338.00
Rip Rap, Plain	10	TN	\$ 75.00	\$ 750.00
Restoration Materials	1	LS	\$ 350.00	\$ 350.00
Material Subtotal				\$ 10,810.28
Sales Tax (6%)				\$ 648.62
Materials Cost				\$ 11,458.90

Subcontractor

Description	Qty	UOM	Rate	Amount
Semi-Lead	6	HR	\$ 140.00	\$ 840.00
GPS Model Revision	4	HR	\$ 100.00	\$ 400.00
Dewatering	1412	FT	\$ 29.00	\$ 40,948.00
				\$ -
				\$ -
				\$ -
Subcontractor Cost				\$ 42,188.00

SUMMARY

	Cost	MU%	Markup	Total
Labor & Equipment	\$ 13,340.11	10%	\$ 1,334.01	\$ 14,674.12
Materials	\$ 11,458.90	10%	\$ 1,145.89	\$ 12,604.79
Subcontractors	\$ 42,188.00	5%	\$ 2,109.40	\$ 44,297.40
Subtotal Cost				\$ 71,576.31
Bond	\$ 71,576.31	1.20%		\$ 858.92
Total Cost				\$ 72,435.22

Description of Work: Bulletin #1; Section 09 - Eliminate Irrigation Valve Boxes and Quick Coupler Valve Assemblies; Furnish new non-freeze ground hydrant near home grandstand, locate and extend water supply line up to 50ft and connect to ground hydrant
 Work Dates: TBD

Labor & Equipment

Description	Labor			Description	Equipment				
	Hours	Rate	Amount		Units	UOM	Rate	Amount	
Laborer - QCV Credit	-10.0	Reg	\$ 75.00	\$ (750.00)	Pickup - QCV Credit	-5.0	HR	\$ 25.00	\$ (125.00)
				\$ -					\$ -
Laborer - Ground Hyd.	16.0	Reg	\$ 75.00	\$ 1,200.00	CAT 305 Mini-Excavator	4.0	HR	\$ 28.72	\$ 114.88
Operator - Ground Hyd.	6.0	Reg	\$ 82.00	\$ 492.00	Pickup	9.0	HR	\$ 25.00	\$ 225.00
				\$ -					\$ -
				\$ -					\$ -
				\$ -					\$ -
				\$ -					\$ -
				\$ -					\$ -
				\$ -					\$ -
Labor Cost				\$ 942.00	Equipment Cost				\$ 214.88

Materials

Description	Qty	UOM	Rate	Amount
Quick Coupler Valve Matl	-1	LS	\$ 600.00	\$ (600.00)
J.R. Smith Ground Hydrant	1	EA	\$ 1,440.00	\$ 1,440.00
Misc Pipe & Fittings	1	LS	\$ 200.00	\$ 200.00
				\$ -
				\$ -
				\$ -
				\$ -
				\$ -
				\$ -
Material Subtotal				\$ 1,040.00
Sales Tax (6%)				\$ 62.40
Materials Cost				\$ 1,102.40

Subcontractor

Description	Qty	UOM	Rate	Amount
				\$ -
				\$ -
				\$ -
				\$ -
Subcontractor Cost				\$ -

SUMMARY

	Cost	MU%	Markup	Total
Labor & Equipment	\$ 1,156.88	10%	\$ 115.69	\$ 1,272.57
Materials	\$ 1,102.40	10%	\$ 110.24	\$ 1,212.64
Subcontractors	\$ -	5%	\$ -	\$ -
Subtotal Cost				\$ 2,485.21
Bond	\$ 2,485.21	1.20%		\$ 29.82
Total Cost				\$ 2,515.03

Description of Work: Bulletin #1 Section 11 -Saw & Remove HMA Pavement, Pothole Utilities, Remove Existing Storm Sewer, Furnish 260 LF 12" Storm Sewer and 2ea 2ft DIA Drainage Structures with Covers and disposal of excess spoils and demolded materials. Restore agg base for pavement removal area. Excludes replacment of fencing and HMA pavement necessary for this item.
 Work Dates: TBD

Labor & Equipment

Description	Labor			Description	Equipment				
	Hours	Rate	Amount		Units	UOM	Rate	Amount	
Laborer	63.0	Reg	\$ 75.00	\$ 4,725.00	CAT 320E	25.0	HR	\$ 109.54	\$ 2,738.50
Operator	59.0	Reg	\$ 82.00	\$ 4,838.00	CAT 950H	15.0	HR	\$ 74.61	\$ 1,119.15
			\$ -		CAT D5K2	15.0	HR	\$ 46.07	\$ 691.05
			\$ -		CAT 257	4.0	HR	\$ 32.55	\$ 130.20
			\$ -		Crew Pickup	25.0	HR	\$ 25.00	\$ 625.00
			\$ -		Diesel Plate Compactor	20.0	HR	\$ 20.00	\$ 400.00
			\$ -						\$ -
			\$ -						\$ -
			\$ -						\$ -
Labor Cost			\$ 9,563.00		Equipment Cost				\$ 5,703.90

Materials

Description	Qty	UOM	Rate	Amount
12" CI IV Conc. Storm Pipe	260	FT	\$ 18.00	\$ 4,680.00
Dr Structure, 24" DIA	2	EA	\$ 775.00	\$ 1,550.00
EJ 1040Z Frame/1040M1 Grate	2	EA	\$ 469.00	\$ 938.00
Brick & Mortar	1	LS	\$ 150.00	\$ 150.00
Geotextile Joint Wrap	1	ROLL	\$ 125.00	\$ 125.00
21AA Limestone	50	TN	\$ 16.50	\$ 825.00
			\$ -	
			\$ -	
Material Subtotal				\$ 8,268.00
Sales Tax (6%)				\$ 496.08
Materials Cost				\$ 8,764.08

Subcontractor

Description	Qty	UOM	Rate	Amount
Semi-Double	5	HR	\$ 165.00	\$ 825.00
Dewatering	260	FT	\$ 29.00	\$ 7,540.00
Vactor Truck	8	HR	\$ 275.00	\$ 2,200.00
Sawcutter for HMA	3	HR	\$ 175.00	\$ 525.00
Subcontractor Cost				\$ 11,090.00

SUMMARY

	Cost	MU%	Markup	Total
Labor & Equipment	\$ 15,266.90	10%	\$ 1,526.69	\$ 16,793.59
Materials	\$ 8,764.08	10%	\$ 876.41	\$ 9,640.49
Subcontractors	\$ 11,090.00	5%	\$ 554.50	\$ 11,644.50
Subtotal Cost				\$ 38,078.58
Bond	\$ 38,078.58	1.20%		\$ 456.94
Total Cost				\$ 38,535.52



Project: 22-S-MI036 - Fruitport High School - 22-S-MI036
357 N 6th AVE
Fruitport, Michigan 49415

Prime Contract Potential Change Order #001: CE #001 - COR#1 For Bulletin #1

TO: Matt Hulswit	FROM: Doug Kent
PCO NUMBER/REVISION: 001 / 0	CONTRACT: 1 -
REQUEST RECEIVED FROM:	CREATED BY: Douglas Kent (Sprinturf)
STATUS: Pending - In Review	CREATED DATE: 5/2/2022
REFERENCE:	PRIME CONTRACT CHANGE ORDER: None
FIELD CHANGE: No	
LOCATION:	ACCOUNTING METHOD: Amount Based
SCHEDULE IMPACT:	PAID IN FULL: No
EXECUTED: No	SIGNED CHANGE ORDER RECEIVED DATE:
	TOTAL AMOUNT: \$177,622.00

POTENTIAL CHANGE ORDER TITLE: CE #001 - COR#1 For Bulletin #1

CHANGE REASON: Client Request

POTENTIAL CHANGE ORDER DESCRIPTION: (The Contract Is Changed As Follows)

CE #001 - COR#1 For Bulletin #1

Scope for 8" Infield Drain tile as modified by Bulletin #1 (owner change) :

- Install Perforated drain tile and Geotextile Fabric according to LD1.01/Det 6 (Fabric & Drain tile furnished by Sprinturf)
- Excavation, Hauling and Disposal of spoil dirt generated by this work.
- Furnish & Install 'Base Aggregate' according to Sheet LD1.01/Det 6
- Dewatering

Breakdown of subcontractor costs for work to performed for scope of bulletin #1:

Labor and Equipment: \$76,257.63
 Materials : \$95,919.17
 Subcontractors: \$16,224.20
 TOTAL: \$188,401.00

ATTACHMENTS:

#	Budget Code	Description	Amount
1		COR#1 Bulletin #1 Excavation Sub	\$188,401.00
2		COR#1 Bulletin #1 Base Sub Scope Changes	\$(7,759.00)
3		COR#1 Bulletin #1 Material Scope Changes	\$(3,020.00)
Grand Total:			\$177,622.00

SIGNATURE

DATE

SIGNATURE

DATE

SIGNATURE

DATE

**BP1 HS ATHLETIC IMPROVEMENTS
PURCHASE ORDER SUMMARY
CONSTRUCTION MANAGER OWEN-AMES-KIMBALL CO.**

	BID CATEGORY	CONTRACTOR	Ltr Intent	CO #1	TOTAL
1	Bid Category No.01 – Synthetic Turf	SprinTurf	744,320	177,622	921,942
2	Bid Category No.02 – Earthwork	McCormick Sand	551,100	134,271	685,371
3	Bid Category No.03 - Asphalt Paving	LiteLoads	378,505	6,895	385,400
4	Bid Category No.04 - Fencing	M&M Fencing	184,324	225	184,549
5	Bid Category No.05 - Concrete	Burgess Concrete Construction	247,455		247,455
6	Bid Category No.06 – Track Coatings	Goddard Coatings	173,000		173,000
7	Bid Category No.07 – Tennis Coatings	Goddard Coatings	63,500		63,500
8					0
9					0
10					0
11					0
12					0
13					0
14					0
15					0
16					0
25					0
26	Allowances				0
27	Connection to existing storm system		150,000	(150,000)	0
28					0
29					0
35					0
36	General Conditions & Reimbursable	Owen-Ames-Kimball	172,308		172,308
37	CM Fee	Owen-Ames-Kimball	111,910	7,099	119,009
		Billing Subtotal	2,776,422	176,112	2,952,534
	Building Contingency		266,451	(176,112)	90,339
	Furnishings & Equipment				0
	Technonolgy				0
	Infrastructure				0
	Wide Area Network				0
	Land Acquisition				0
	Architectural Fees				0
	Survey\Borings				0
	Asbestos				0
	Reimbursables				0
	Builders Risk Insurance				0
	Consultants				0
	Plan review				0
	Misc.				0
	TOTAL		3,042,873	0	3,042,873
	Bond Budget				0